

**USB - Torque Sensor with Configuration and Evaluation Software****DR-3000**

- Measuring ranges 0.5 ... 5000 N-m
- Up to 2500 Measurements/s
- 16-Bit digitalization in sensor directly
- Feed-in from USB, without ext. power supply
- Speed up to 30,000 min⁻¹
- Suited for mobile operation with a notebook
- Calibration parameter lodged in sensor
- Calibration control actuation by software
- Power computation by software
- Virtually no influence of the bearing friction on the measuring signal



This sensor has a contactless and digital signal transmission from rotor to stator, which means no signal falsification and maintenance-free.

Article Number	Measuring Range [N·m]	Weight approx. [kg]	Max. Speed [min ⁻¹]	Springrate [N·m/rad]	Mass moment of Inertia [kg·m ²]		Natural Frequency [Hz]
					Drive side	Test side	
111231	0.5	0.5	30000	1.2E+02	1.1E-05	1.8E-07	4.1E+03
111177	1	0.5	30000	1.2E+02	1.1E-05	1.8E-07	4.1E+03
111232	2	0.5	30000	3.2E+02	1.1E-05	1.8E-07	6.7E+03
111233	5	0.5	30000	5.6E+02	1.1E-05	1.9E-07	8.6E+03
111234	10	0.6	30000	5.9E+02	1.1E-05	2.0E-07	8.9E+03
111235	20	1.5	20000	4.4E+03	1.2E-04	6.8E-06	4.2E+03
111236	30	1.5	20000	4.4E+03	1.2E-04	6.8E-06	4.2E+03
111114	50	1.5	20000	8.2E+03	1.2E-04	7.3E-06	5.5E+03
111237	100	1.5	20000	8.2E+03	1.2E-04	7.3E-06	5.5E+03
111238	200	4.8	15000	7.3E+04	5.6E-04	4.5E-04	2.7E+03
111239	300	4.8	15000	7.3E+04	5.6E-04	4.5E-04	2.7E+03
110554	500	4.8	15000	7.3E+04	5.6E-04	4.5E-04	2.7E+03
111240	1000	5.1	15000	1.6E+05	6.6E-04	5.4E-04	3.6E+03
112801	2000	19	12000	6,4E+05	5,8E-03	5,1E-03	2,4E+03
112802	3000	19	12000	7,4E+05	5,8E-03	5,2E-03	2,6E+03
112803	5000	19	12000	8,2E+05	5,9E-03	5,2E-03	2,7E+03

Please specify the required meas. range at order!

**SPECIFICATIONS**

Type		DR-3000
Accuracy class torque	% f. s.	0.1
Speed resolution	min ⁻¹	1
Speed accuracy	% f. s.	<1
Angle of rotation resolution	degree	0.25
Repeatability acc. DIN 1319	%	±0.02
Feed-in from USB	V DC	4 ... 6
Current consumption	mA	<250
Output signal torque	digits	±25,000
Output signal speed / angle of rotation	digits	±32,511
Input calibration control actuation		per Software
Sample rate	kSample	2.5
Reference temperature	°C	+23
Nominal temperature range	°C	+5 ... +45
Service temperature range	°C	0 ... +60
Storage temperature range	°C	-10 ... +70
Temperature coefficient of characteristic value	% f. s./K	+0.01
Temperature coefficient of zero signal	% f. s./K	±0.02
Service torque (static)	% f. s.	150
Limit torque (static)	% f. s.	200
Ultimate torque (static)	% f. s.	>300
Oscillation amplitude (DIN 50 100)	%	70 (peak - peak)
Level of protection (DIN EN 60529)		IP50
Electrical connection		PX0446 IP68 B Mini USB, incl. 3 m connection cable to PC

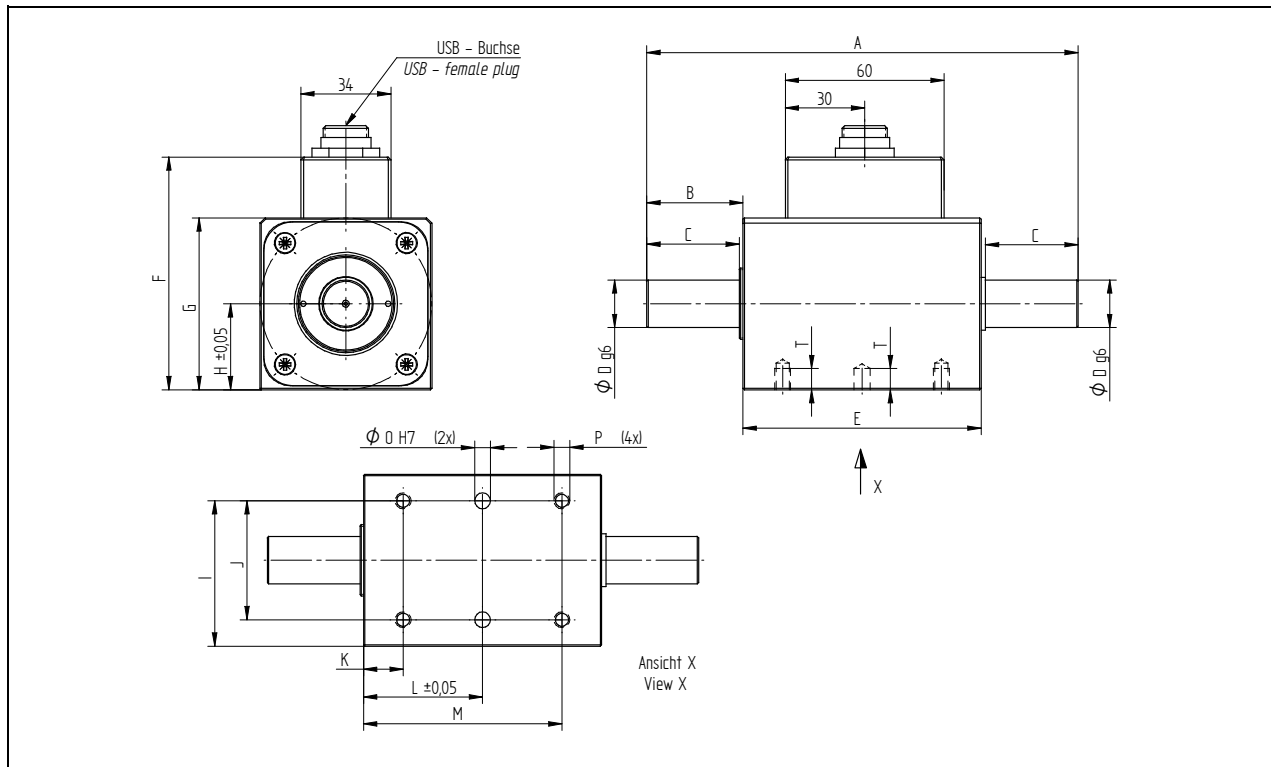
Dimensions**DR-3000**

Measuring range [N·m]	Dimensions [mm]															
	A	B	C	Ø D	E	F	G	H	I	J	K	L	M	O	P	T
0,5 / 1 / 2 / 5	110	19	17	8	71	63	40	20	35	30	12	35,5	59	4	M4	8
10	110	19	17	10	71	63	40	20	35	30	12	35,5	59	4	M4	8
20 / 30 / 50 / 100	163	36,5	35	18	90	88	65	32,5	55	45	15	45	75	6	M6	8
200 / 300 / 500	234	56,5	55	32	120	118	95	47,5	82,5	70	20	60	100	8	M8	14
1000	234	56,5	55	42	120	118	95	47,5	82,5	70	20	60	100	8	M8	14
2000 / 3000 / 5000	372	114	110	70	144	163	140	70	120	100	25	72	119	12	M12	20

**Configuration and Evaluation Software****DR-3000-VS**

- Convenient configuration and evaluation software
- Graphic presentation of torque/ speed/ power or torque/ angle of rotation
- Automatic scaling of y-axis
- Simultaneous storage of up to 3 physical values
- Automatic storage function of the measured values as CSV- or BMP-File

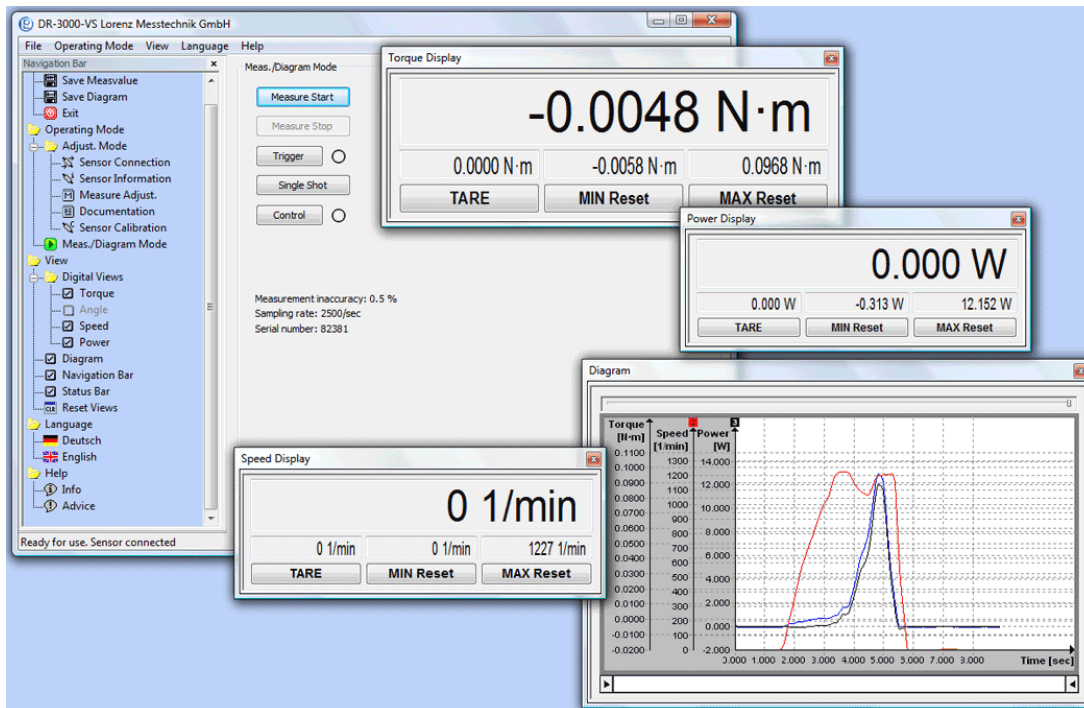
**DESCRIPTION**

Configuration and evaluation software for easy analysis and graphic presentation on a PC.

The software for the DR-3000 allows direct read in of measured data into a text file in CSV-Format through the USB-Port of a PC. This enables further analyses with a commercially available spreadsheet program at any time.

SPECIFICATIONS

Type	DR-3000-VS
Interface	USB (for operation with DR-3000)
Protocol	Lorenz standard protocol
System requirements	ex Win2000 ^{®1} Single- Core ex 2.0 GHz (without diagram) Dual- Core ex 1.8 GHz (with diagram)

Conversion in physical values	✓
Simultaneous measuring	1 Sensor
Graphic presentation of a physical value	✓
Automatic or manual storage in a CSV and BMP file	✓
Mathematical computation of the mechanical power	✓
Calibration function	✓
Resettable minimum value memory for each measured value	✓
Resettable maximum value memory for each measured value	✓
Variable average determination	✓
Tare for each measured value	✓

¹ Windows[®] is either a registered brand or brand of the Microsoft Corporation in the USA and/or other countries.